

NOTES

1. DO NOT SCALE FROM THIS DRAWING.
2. REFER TO DRAWINGS S-1000 FOR GENERAL NOTES.
3. THE CONTRACTOR SHALL CHECK ALL DIMENSIONS ON SITE PRIOR TO FABRICATION.
4. ALL CONNECTIONS ARE TO BE MIN. 6mm FILLET WELDS UNLESS NOTED OTHERWISE.
5. ALL STEELWORK CONNECTION BOLTS TO BE MIN. M16 BOLTS GRADE 8.8 UNLESS NOTED OTHERWISE.
6. SIZES OF ALL STEELWORK INDICATIVE AND ARE SUBJECT TO CHANGE ON ALL DETAILED DESIGN. FOR CONSTRUCTION ISSUE.
7. FOR GALVANISING, POWDER COATING AND STEEL GRADERS REFER TO GENERAL NOTES DRAWING S-1000.
8. CONCRETE GRADE TO BE GEN.3.
9. THE CONTRACTOR IS TO UNDERTAKE THEIR OWN SURVEY FOR THE PRODUCTION OF FABRICATION DRAWINGS.
10. SOUTHAMPTON CITY COUNCIL TO REVIEW AND COMMENT PRIOR TO COMMENCEMENT OF FABRICATION.
11. FOR SPECIFICATION REFER TO NRS, DESIGNERS RISK ASSESSMENT AND SCOPE OF WORKS AND ADDITIONAL SPECIFICATIONS.

SPICE JOINT TO BE ABOVE BALCONY SLAB IN FINAL SCHEME

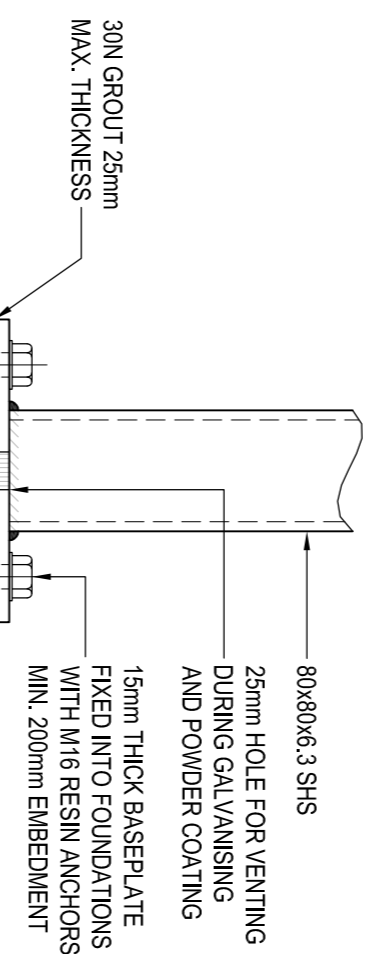

TYPICAL BASEPLATE DETAIL
1:5

Rev	Date	Amendments	By	Chk	Appr
T1	10.03.17	TENDER ISSUE	AF	CT	DH

Drawing Status: **TENDER**

Client: **SOUTHAMPTON CITY COUNCIL**

Project Title: **CANTILEVER BALCONY SUPPORT LOT 1 - D.O.R. BLOCKS**

Drawing Title: **TYPICAL 4 STOREY ELEVATION, SECTIONS AND DETAILS**

Project No.: **RP200058** Drawing No.: **S-1100** Rev: **T1**

Date: **MAR-17** Scale: **AS SHOWN @ A1**

By: **AF** Checked: **CT** Approved: **DH**

UPR Number: .