

**part 9**  
**waste**  
**management**

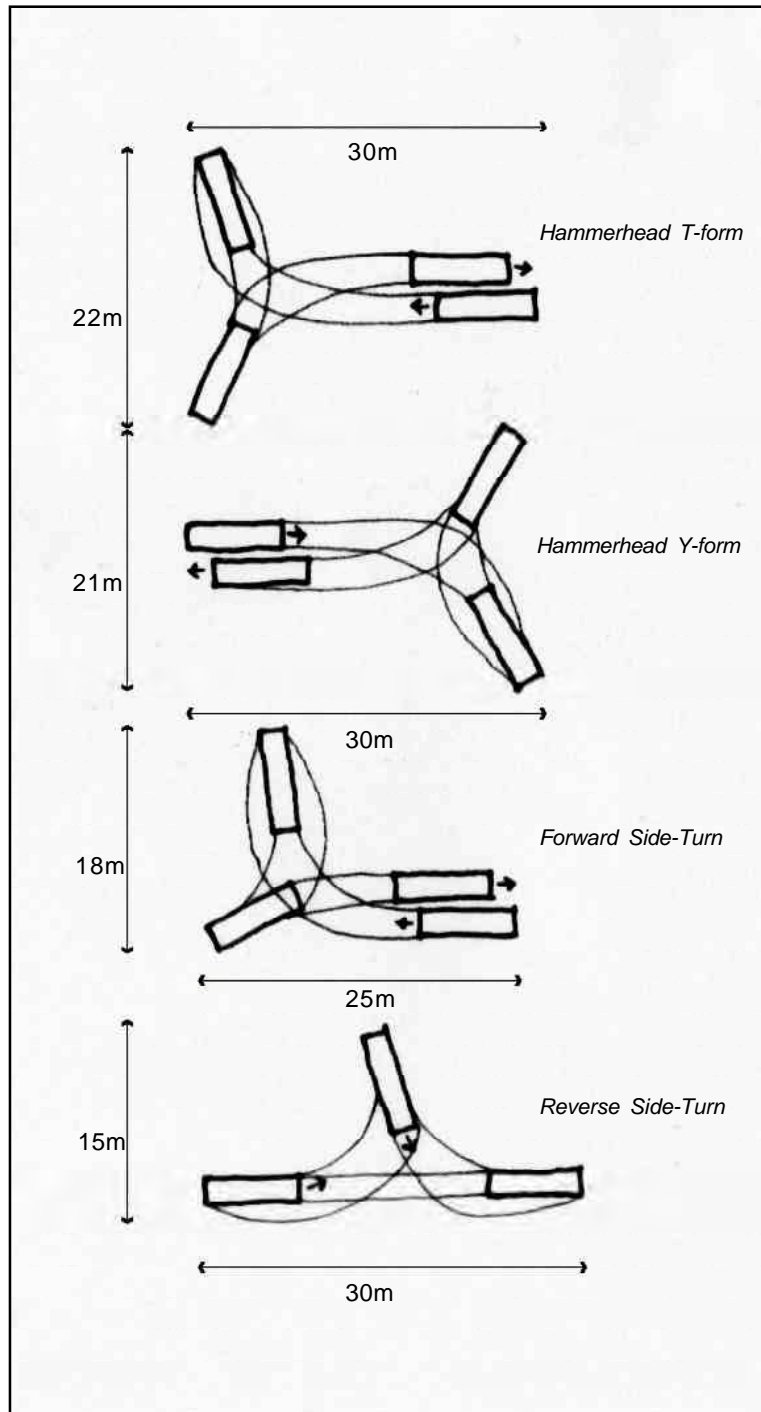



Above: Recommended turning circles for waste collection vehicles

Dimensions of a standard refuse vehicle	
Gross Weight	26000 kg
Overall Length	9415 mm
Overall Width	2500mm
Overall Height	3410mm
Height - tail gate up	4500 mm
Rear Overhang	2490 mm
Turning Circle	19100 mm (kerb to kerb)

## 9 WASTE MANAGEMENT

### 9.1 Introduction

- 9.1.1 The UK Landfill Directive requires a reduction in the amount of material being sent to landfill and increased re-use, recycling, and composting for more sustainable management of waste streams.
- 9.1.2 The City Council specifies that householders store two wheeled bins; one for mixed dry recyclables and the second for general waste. From 2006 households may also have containers for glass kerbside collections.
- 9.1.3 Provision for the adequate storage and collection of domestic waste and recyclables, and storage for composting is expected to be included in the layout of all new developments. Extensions to existing properties must not remove such facilities.

### 9.2 Adequate space should be provided for separate bins to facilitate the sorting and storage of household waste within both the internal and external layout of homes.

Space should be provided for containers for:

- General waste;
- Mixed dry recyclables (plastic, paper, cardboard, tins);
- Glass.

Storage space should also be provide for:

- Composting facilities;
- Garden waste;
- Large bulky goods (in complexes with 25 units and over).

- 9.2.1 For internal provision, containers should be integrated into the layout of the kitchen and/or utility space (within a storage unit) as this will encourage the householders to recycle waste without the need for untidy boxes on the floor. The in-built facilities should incorporate boxes that have a hinged lid and be designed to be carried to the outside recycling facility of the development.



*No consideration has been given to adequate storage provision for these wheelie bins*

*Previous page: The boundary wall provides an enclosure to hide wheelie bins from general view - Basingstoke*

9.2.2 Residents must have access to an outside storage area for movable (individual or communal) waste, mixed dry recycling, and recycling containers, meeting the requirements of the waste collection authority specified in the following table:



Full height storage areas are suitable for bins serving several residents



These underground waste storage systems in Amsterdam are an innovative way of containing waste discretely, however any proposals to use similar facilities should be discussed with the Waste and Recycling Manager

Requirements for external provision of refuse containers	
Households with less than 6 residents	2 x 240 litre Wheeled bin (one with green lid, one with blue lid)
Households with 6 or more than 6 residents	2 x 360 litre Euro bin (one with green lid, one with blue lid)
For every 9 flats	2 x 1100 litre Euro bin (one with green lid, one with blue lid)
For every 25 units	Storage area for discarded bulky items (e.g. White goods & furniture) <i>This should be lockable and animal proof. Special collections can be arranged with the waste collection department for these large items</i>
All households should also be allocated appropriate external space for:	<b>Glass-storage container</b> <b>Composting facilities for</b> domestic green waste (individual for householders / communal for flatted developments)  Ideal composting areas are located away from the building and are relatively cool in the summer and warm in winter. Compost bins should sit directly onto the soil to allow access for worms, soil, microbes and drainage  The incorporation of in-vessel composters will work best where a development has its own management arrangements for common areas and public space. They can be located adjacent to the recycling points and ideally, where these are within detached, storage buildings
In some circumstances it may be necessary to use alternative sizes of bin. Advice is available from the local waste collection authority through 023 8083 3005 on matters including suitable provision, suitable collection points, and prices of containers	

Dimensions of refuse containers			
Type	Height	Width	Depth
Wheeled 240 litre	1075 mm	580 mm	728 mm
Wheeled 360 litre	1100 mm	600 mm	874 mm
Euro bin 1100 litre	1300mm	1370 mm	960 mm

The table above is for guidance only as sizes may vary slightly depending on manufacturer

9.2.3 The council expects the developer to meet the cost of providing bins to housing developments and apartment blocks. Prior to purchase of the bins the developer should contact the City Council to request a detailed specification.

9.2.4 **The waste storage areas should be sited and designed to enable residents and collection workers to conveniently and safely access waste containers.**

9.2.5 Storage areas for waste containers must be sited so that the distance householders are required to carry refuse from their dwelling does not exceed 30 metres (excluding any vertical distance).

9.2.6 When designing the necessary allocated space for communal bin storage in a development there must be sufficient space between and around the containers for manoeuvring and cleaning purposes (a minimum of 150 mm). If Euro bins are to be positioned facing each other there must be a minimum of 1000 millimetre clearance between the two bins.

# waste management

## 9.3 The waste storage areas should be sited and designed to enable residents and collection workers to conveniently and safely manoeuvre waste containers to the collection point.

9.3.1 Bins must be placed at the collection point or street (where no collection point has been specified by the waste collection authority) on the collection day. The collection point should be located so that the containers do not present an obstruction to the access of properties or inconvenience to users of the highway.

9.3.2 Waste stores must be sited so that containers can be taken to the collection point without being taken through a building. Smooth surfacing and suitable lighting should be provided in the storage area and up to its collection point. Steps should be avoided between the store and collection point, however a maximum of three steps is acceptable for bins up to 250 litres. For bins over 250 litres, steps are not permitted. The maximum slope allowed is 1:12 but exceptionally this may be exceeded provided that the lengths are not excessive and it is not part of a series of slopes.

9.3.3 The collection point must be located near to the highway so that collection workers have to move the container no more than 10m to the rear of the vehicle for emptying. Paths between the storage areas and collecting vehicles should be free from kerbs (drop kerbs are acceptable with, if possible, a no parking area) or steps and be supplied with a hard wearing surface that will withstand the loadings imposed by the container wheels.

9.3.4 Where the collection point or communal bin store is not within 10m of the highway appropriate hard-surfaced access and manoeuvring space must be provided in order that refuse vehicles can gain access to the collection point. Usually the maximum slope for the access to the highway from the collection point is 1:20. The vehicular access should be a minimum of 4.1m wide for the first 7m length of the access. This is to allow vehicles entering or leaving the site to pass one-another without congesting the main highway and inconveniencing those drivers leaving the site. Applicants should work to the size of the vehicle in the accompanying table and provide a tracking diagram (superimposed on a site layout plan to a scale of no less than 1:500) to demonstrate this.

9.3.5 Responsibility for the transfer of bins to and from the collection point should be determined from the initial stages of planning the development.



*Waste storage areas should be provided to prevent eye-sores such as this*



*This galvanised metal fencing is attractive but is not designed to conceal the wheelie bin*



*Waste storage appears to have been an afterthought for both of these developments (above and below)*



*A free standing building provided for waste storage has been planned as part of the landscape and parking layout. However the side walls of the building could have been softened by evergreen shrubs - Fareham*

**9.4** The detail design of bin storage facilities should be submitted as part of the planning application. A waste management plan may be required as part of a Section 106 agreement. Innovative solutions are sought that are integral to the design of the development, its landscape setting and that make a positive contribution to enhancing the character of the area.

**9.4.1** The waste storage area should be an integral part of the building structure or if free standing, a properly constructed enclosure in a convenient but inconspicuous position to the side or rear of the building, planned as an integral part of the landscape plan. Areas should be screened and shaded. A position forward of the frontage building line will only be accepted if there is no viable alternative. In some circumstances underground storage of waste and recyclables could solve some of the storage issues in high-density residential areas.

**9.4.2** Bins should not be stored in full public view or visible from a public highway.

**9.4.3** Where the store is located in a publicly accessible area or in an open area around a building, it is desirable for aesthetic reasons to screen the storage area with planting, railings, gates and low-rise walls to minimize the impact. Screening must be provided to a height of at least 450mm above the top of the bins, and the area should be clearly signposted. A storage shelter may have appropriate roofing, and should be sufficiently high to allow the lid to be opened for filling without the withdrawal of the container. Doors should always open outwards and in the open position allow easy manoeuvring of bins but should not obstruct any footway or vehicular access. Double doors may be provided but these must allow sufficient space for manoeuvring the container out of the store.

**9.4.5** Storage areas must be located and designed in a manner that avoids disturbance by noise, odour, visual intrusion, attraction to pests and vermin, or loss of privacy, resulting from the comings and goings of refuse collectors, and that allows for easy maintenance of the area and containers.

**9.4.6** Storage areas must have a hard-surfaced, impervious floor that incorporates appropriate drainage to enable adequate cleaning of the containers and storage area. The drainage must be designed to ensure that waste water discharges into a sewer and does not contaminate the surrounding ground or natural water systems.

**9.4.7** Storage enclosures must be permanently ventilated at the top and bottom to avoid odour problems. Where the storage area is separate from the main building, the store should be located away from windows and ventilators.